

Installation and Operating Instructions 0158

0093.112.00 a

Lumistar Luminaire 'Lumiflex' ESL55LED-ALF-Ex

 II 2G Ex db IIC T6 Gb
II 2D Ex tb IIIC T80°C Db

• Important, please note:

The Lumistar luminaire 'Lumiflex' can be mounted on sight glass fittings or used for illuminating individual objects, e. g. on machine tools. Ex-classified luminaires with light guide are also intended for observing processes in reactors, plants, vessels, etc., wherever the use of standard Ex-type luminaires is not possible due to space restrictions. Under no circumstances should a sight glass luminaire be utilised to replace the cover flange or the complete sight glass flange fitting or used on its own to cover a vessel port. Luminaires for potentially explosive areas must always be installed, connected and serviced by persons who have been specially trained and authorised to do this work.

• General operating conditions:

- Independent of internal pressure/vacuum in the vessel in applications as a sight glass luminaire
- Approved for use in potentially explosive environments:
- Gas: Zones 1 and 2; Dust: Zones 21 and 22
- Also suitable for illumination purposes in Zones 0 and 20 in combination with a sight glass
- To ensure faultless operation, the specified temperatures must be observed
- Approved for applications at ambient temperatures of between -20°C and +50°C
- Temperature-resistance of light guide: -20°C to +150°C

• Electrical data – general:

- The voltage, output, temperature class and protection class are specified on the type plate
- Voltage and wattage: 24 V AC/DC or 120-230 V AC, 7 W
- IP65 and IP67 acc. to EN 60529/DIN VDE 0470 Part 1
- Ex approval acc. to EC type examination certificate: BVS 14 ATEX E 172 X

 II 2G Ex db IIC T6 Gb
II 2D Ex tb IIIC T80°C Db

- Compliance with the data in the EC type examination certificate is mandatory!
- Type of voltage: AC and DC

• Electrical connection:

a) ESL55LED-ALF-Ex with connecting cable

- The connecting cable has already been works-fitted in the luminaire so that it is ready for operation.
- The external protective terminal conductor (part 1.3) must be connected to a separate ground terminal.
- The connecting cable should be supported and fixed after a maximum distance of 1 metre.
- If the cable is being replaced, the inner terminals should be loosened prior to removing the cable entry gland.

Operating conditions:

Ex-type luminaires are manufactured with a permanently connected cable. The free ends of the connecting cable must be installed in a class 2G/2D housing if connection is carried out in the potentially explosive area. Prior to installing the luminaire or during maintenance work on it, both the luminaire and the surrounding area should be cleared of dust. The dismantled parts should be protected against dirt and dust during installation and maintenance work. When closing the luminaire, it is essential to take care that there is no dust inside. For applications in areas where there is a risk of dust explosions, the connecting cable should be laid so that it is protected against electrostatic discharge.



Lumistar luminaire 'Lumiflex' ESL55LED-ALF-Ex

The ferrite core included in the scope of supply should be used with connecting variants b and c. All connection wires need to be wound a full turn around the core. In the case of the 24 V variant, the ferrite core should be slid onto the cable at a distance of around 10 mm from the cover.

b) ESL55LED-ALF-Ex with cable gland (sealing compound)

- select a connecting cable to fit cable gland M20x1.5 and take account of the cable diameter (8-11 mm)
- The minimum temperature resistance of the connecting cable must be observed (-20°C/+85°C)

c) ESL55LED-ALF-Ex (tested combination)

- The following cable glands and cables **must** be used in combination:

Cable gland types	Installation torques	
HSK-M-Ex-d, part no. 9103.124.00 M20x1.5 1.4404 (from Hummel)	7.0	2.5
KU1BPM20-Ex-d-Alpha X, part no. 9103.131.00 M20x1.5, stainless steel (from RST)	6.0	3.0

Cable types
EVA sheathed cable, Sinotherm 110, part no. 3403.017.00 3x1.5 mm ² , Ø 8.5 mm
Ölflex Heat 180, part no. 3403.045.00 3x1.5 mm ² , Ø 8.9 mm
Ölflex Heat 180, Silflex UR-AWG18, part no. 3403.044.00 5x1.0 mm ² , Ø 10.3 mm
Ölflex Classic 110 black, part no. 3403.051.00 3x1.5 mm ² , Ø 10.1 mm

• Please note:

The closure screws for the end cover (M4x12) and luminaire glass lens (M4x40) must have a yield strength of ≥ 240 N/mm² (material: A2-70).

• **Electrical connection:**

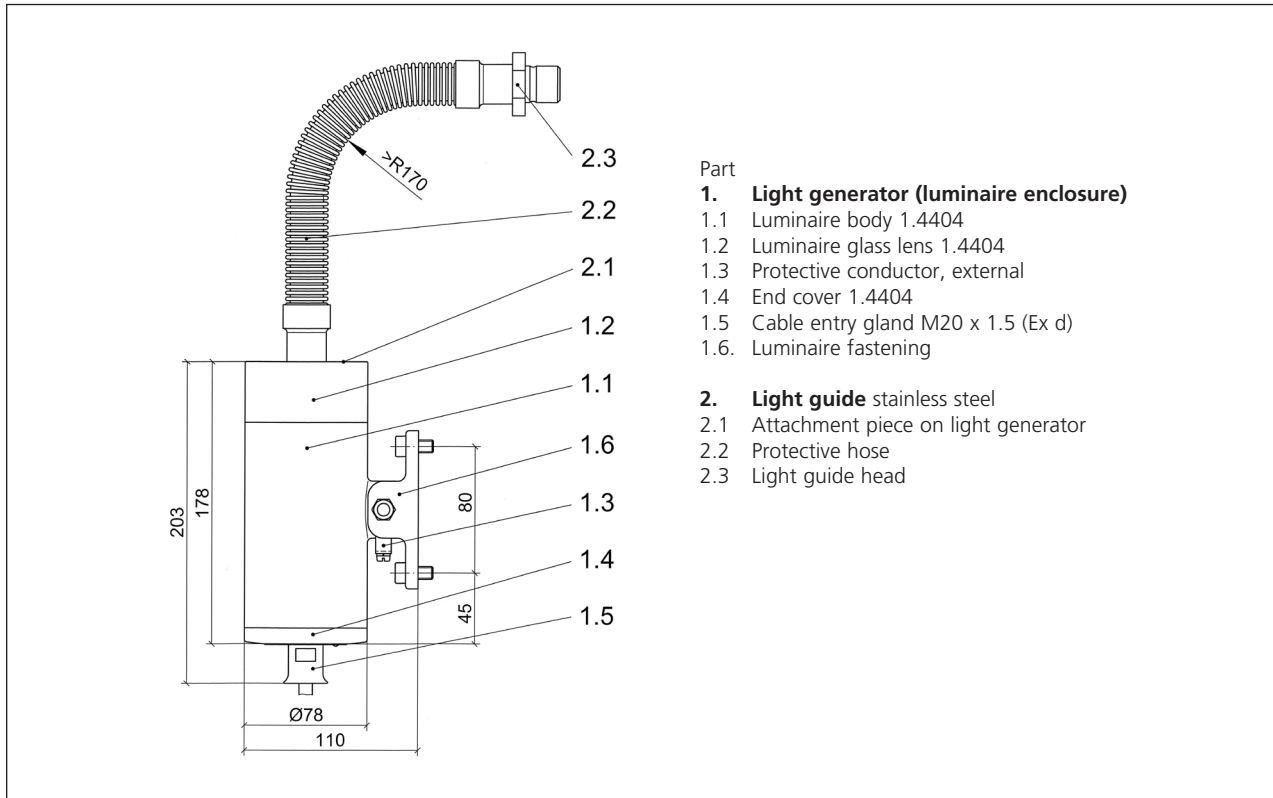

- Part
- 1. Light generator (luminaire enclosure)**
 - 1.1 Luminaire body 1.4404
 - 1.2 Luminaire glass lens 1.4404
 - 1.3 Protective conductor, external
 - 1.4 End cover 1.4404
 - 1.5 Cable entry gland M20 x 1.5 (Ex d)
 - 1.6 Luminaire fastening
 - 2. Light guide stainless steel**
 - 2.1 Attachment piece on light generator
 - 2.2 Protective hose
 - 2.3 Light guide head

• **Mechanical installation:**

- Caution: Avoid looking into the light source – risk of damage to the eyes!
- The light generator (1) is mounted at a suitable place on the reactor, apparatus, etc., using the fastening element provided. The light guide should be mounted free of tension or twisting with a bending radius of at least 170 mm and installed with the light guide head holder.
- The light guide head (2.3) is screwed to the place to be illuminated using the relevant stainless steel fastening unit.

• **Installation position:** as required

• **Replacement parts and accessories:**

- Please use original spare parts only
- Have the luminaire serviced by the manufacturer whenever necessary

• **Maintenance:**

- Keep the luminaire clean
- Once the luminaire has been opened, the thread of the end cover (1.4) should be greased again (e. g. with AEMA-SOL 6 B, made by A.E. Matthes)

Product	Part No.
Fastening for light generator	0354.031.00
Fastening for light guide head	1947.005.00
O-ring seal for light guide	0862.082.00
Light guide 0.5 m	3383.021.00
Light guide 1.0 m	3383.022.00
Light guide 1.5 m	3383.023.00
Light guide 2.0 m	3383.024.00
Light guide 3.0 m	3383.026.00
Connecting cable 2 m	1084.021.00
Connecting cable 10 m	1084.024.00
Replacement parts	
End cover	0821.011.00
Glass lens of luminaire (light outlet)	1773.013.00
Cable gland (Ex d M20 x 1.5) stainless steel	9103.133.00
O-ring seal	0862.090.00
Threaded pin	7446.075.00
Cylinder head screw M4x12 A2-70	6911.358.00
Cylinder head screw M4x40 A2-70	6911.364.00