

SYSTEMATIC QUALITY

# LaneLED GFK

HANDRAIL LIGHTING SYSTEM

Product information

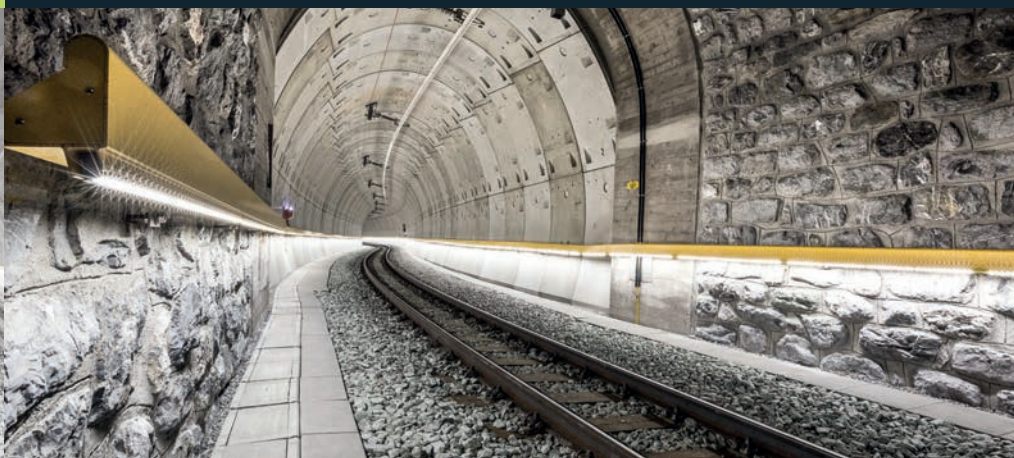

**GIFAS**  
ELECTRIC

**Malux**  
solutions

## «Handrail Lighting System» for self-rescue in the gallery and duct

Various accidents and fires in railway tunnels have shown that the self-rescue measures for passengers and Staff must be improved.

Protection of life and limb – evacuation – firefighting, and initiating protective measures.



This system was developed in cooperation with well-known manufacturers and has been tested to the specifications of the TSI (Technical Specifications for Interoperability – Directive 2008/57 / EC of 17.6.2008).

For the first time the LaneLED GFK Handrail Lighting System enables operators and engineers to install a complete product, tested as a system, which fulfils all technical requirements from the TSI.

The Handrail Lighting System is the first system where the modular components have been successfully tested in fire tests according to **DIN 4102 part 12**. This is the first handrail solution in which the modular components have been jointly tested successfully in fire tests according to DIN 4102 Part 12. The numerous elaborate tests were carried out by the «Materialprüfanstalt Dresden» (MPA Dresden), the corresponding certificates can be sent on request.

**In the interaction of all clearly defined products, the system test E30-E90 of the system components is confirmed!**

Based on guidelines (eg handbook SBB I-20036 «Self-rescue measures in tunnels» or international specifications of the TSI) we developed the following solutions:

### LED illuminated handrail with functional integrity!

Applications:

- railway tunnels
- gallery lighting
- power plant and cavern corridors
- safety tunnels, access and evacuation tunnels
- mines
- versions with or without functional maintenance

Your advantages:

- certified in accordance to DIN 4102 Part 12
- easy and quick installation
- type-tested components
- approved by FOT Switzerland (Federal Office of Transport)

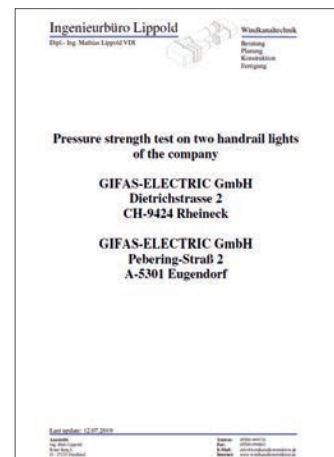
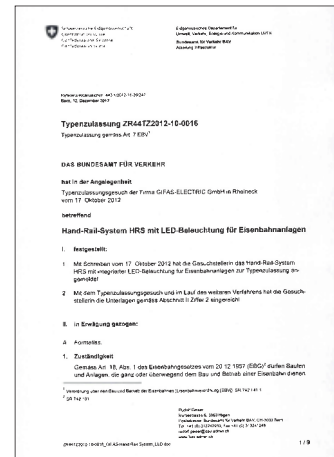
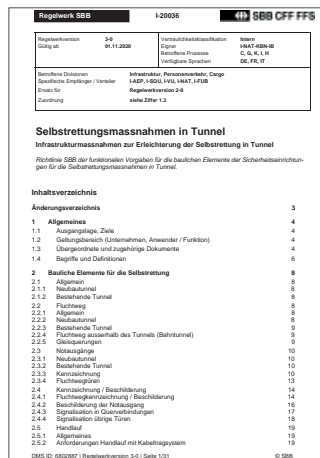

# Handrail Lighting System LaneLED GFK

## Lighting components

- LaneLED light bar in special profile including electrical supply



## Mechanical components

- handrail GFK, fibreglass reinforced plastic
- wall fastening, stainless steel brackets,
- connector and bracket parts

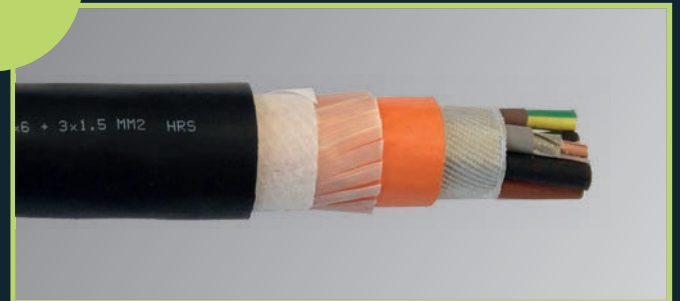
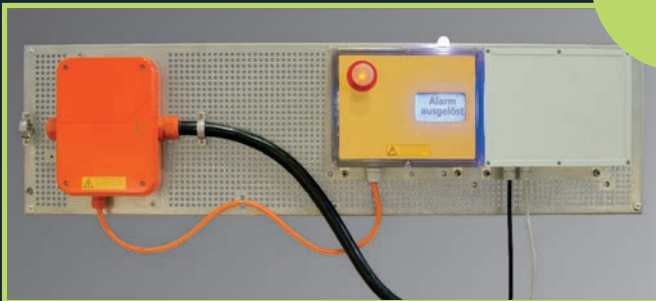
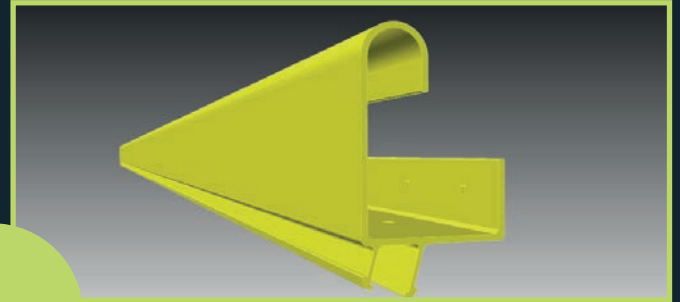

## Safety components

- fire-resistant junction box, fully equipped
- optional alarm unit, individually manufactured
- fire-resistant junction box, fully equipped

## Connecting components

- main or supply cable; project-based for control and supply
- junction, ending and mounting parts



## LaneLED GFK

Handrail with integrated emergency escape route lighting

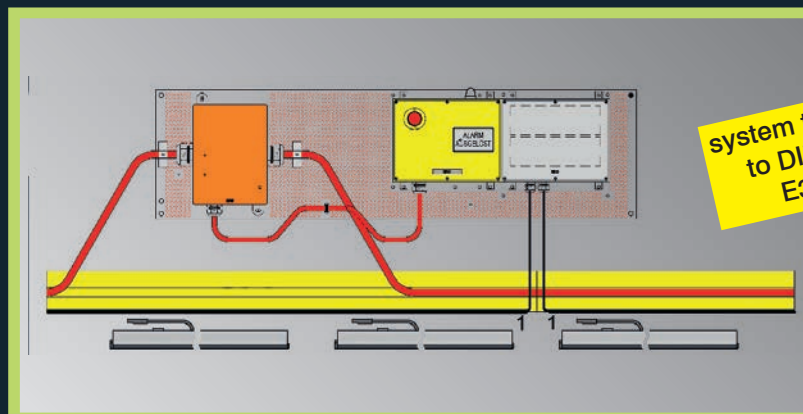

system tested according to DIN 4102 part 12 E30 | E60 | E90

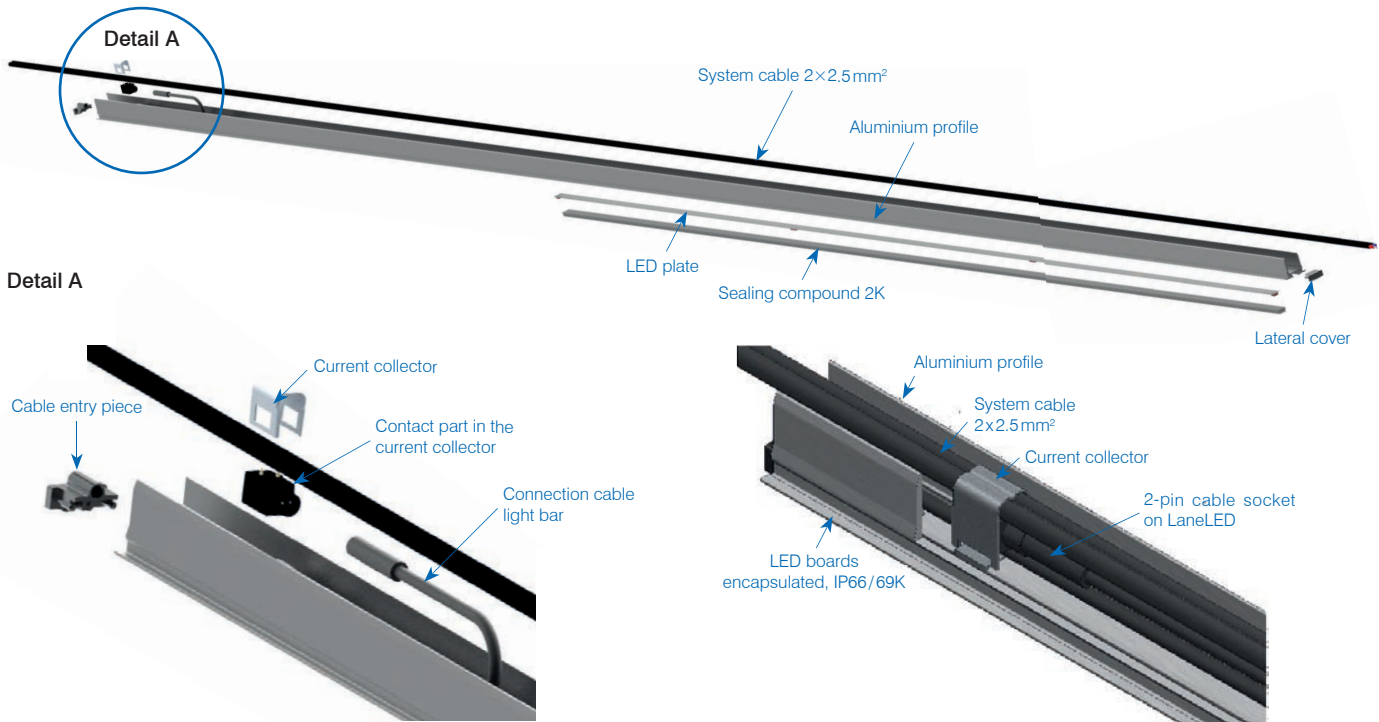

## LaneLED

The «LaneLED» light bar from GIFAS is the base element of the illuminated Handrail System LaneLED GFK. The appropriate type is selected depending on the requirements of the operator, whereas the desired lighting strength is the most important specification. The other parameters of the LaneLED are carefully defined.

- Light colour: 4'400 K
- Beam angle: 120°
- Operating life: L90/B10 100'000 h +25° C
- Protection category: IP66 / 69K
- Impact resistance: IK10
- Operating range of temperature: -25° C to +45° C

## Composition of the LaneLED

The carrier profile of the «LaneLED» light bar consists of a special aluminium profile with special characteristics for mechanical and chemical strains.

A flexible and separable LED strip is inserted from below and incorporated into the aluminium profile with 2 component casting compound. The encapsulation leads to the high protection class of IP66/69K. There is room for the system cable and the current collector in the upper part of the profile (in between the flanks).

## Light bar LaneLED

LaneLED with special anodised aluminium profile, dimensions 30x26mm and length available from 372mm to 2'956mm with LED modules 21-32VDC, 4'400K, beam angle 120°, ready for connection, not including assembly materials (system cable and current collector).

## Illumination

Light emission of LaneLED GFK handrail

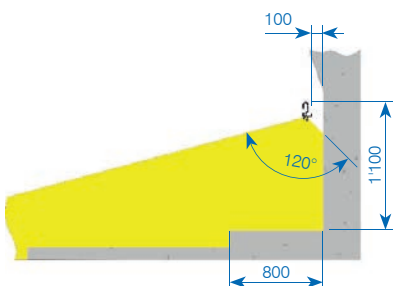

## Current collector

Each individual LaneLED is connected to the power supply by the current collector and is freely attachable to the flat cable 2x2.5mm². The cable bushing serves as the interface to the current collector and the connection cable with plug 2P of the LaneLED (IP66/69K connection).

## Type SNAP

## Type SCREW

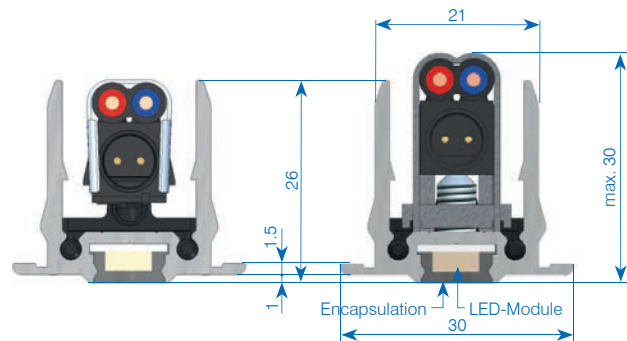

View: Cut of the profile with current collector

## Accessories LaneLED

Item no.	Description
209768	LED, system cable black, 2x2.5mm² flat cable CPR B2ca XLPO/XLPO
209769	LED, system cable blue, 2x2.5mm² flat cable CPR B2ca XLPO/XLPO
209770	LED, system cable red, 2x2.5mm² flat cable CPR B2ca XLPO/XLPO
136230	LED, current collector SCREW 2P, 42V-5A, V4A 1.4401, with metal bracket, thread base plate and set screw
860120	LED, current collector SNAP 2P, 42V-5A, V2A 1.4310 (requires special pliers Item no. 860565)

# Light data / Assortment LaneLED GFK

## Technical data LaneLED – Light comparison measurements

Perfect light for each application! Below table gives you an overview of the light data of LaneLED type 1 - 5.

- maintenance factor: 1 (value as new)
- light mounting height: 95 cm
- emergency escape route width: 1 m

## Standard assortment

Item no.	Length mm	Number of LED	Output W	Power mA	Luminous flux lm
<b>Type 3: LaneLED GFK, 4'400K, 21 -32VDC, 50Lux-95 cm</b>					
860373	372	12	0.5	20	32
860374	1110	36	1.5	60	96
860486	1479	48	2.0	80	128
860487	1848	60	2.5	100	160
860375	2220	72	3.0	120	192

## Type 4: LaneLED GFK, 4'400K, 21 -32VDC, 100Lux-95 cm

860488	372	12	1.0	40	64
860489	1110	36	3.0	120	192
860490	1479	48	4.0	160	256
860491	1848	60	5.0	200	320
860492	2220	72	6.0	240	384

## Type 5: LaneLED GFK, 4'400K, 21 -32VDC, 150Lux-95 cm

860376	372	12	1.5	60	96
860377	1110	36	4.5	180	288
860493	1479	48	6.0	240	384
860494	1848	60	7.5	300	480
860378	2220	72	9.0	360	576

## Type 6: LaneLED GFK, 4'400K, 21 -32VDC, 300Lux-95 cm

860495	372	12	3.0	120	192
860496	1110	36	9.0	360	576
860497	1479	48	12.0	480	768
860498	1848	60	15.0	600	960
860499	2220	72	18.0	720	1150
860731	2956	96	24.0	960	1536

## Redundancy

The redundant LaneLED light bar has two independent lighting circuits, a separate feed-in for every second LED. This ensures that, if one lighting circuit fails (power supply failure, wire breakage, electronics defect, etc.) the LaneLED light bar retains 50% of its functionality.

## Assortment Redundant

Item no.	Length mm	Number of LED	Output W	Power mA	Luminous flux lm
<b>Type 3: LaneLED GFK redundant, 4'400K, 21 -32VDC, 50Lux-95 cm</b>					
860382	374	12	2×0.25	2×10	2×16
860383	1112	36	2×0.75	2×30	2×48
860502	1481	48	2×1.00	2×40	2×64
860503	1850	60	2×1.25	2×50	2×80
860384	2222	72	2×1.50	2×60	2×96

## Type 4: LaneLED GFK redundant, 4'400K, 21 -32VDC, 100Lux-95 cm

860385	374	12	2×0.50	2×20	2×32
860504	1112	36	2×1.50	2×60	2×96
860461	1481	48	2×2.00	2×80	2×128
860505	1850	60	2×2.50	2×100	2×160
860506	2222	72	2×3.00	2×120	2×192

## Type 5: LaneLED GFK redundant, 4'400K, 21 -32VDC, 150Lux-95 cm

860472	374	12	2×0.75	2×30	2×48
860386	1112	36	2×2.20	2×90	2×144
860507	1481	48	2×3.00	2×120	2×192
860508	1850	60	2×3.80	2×150	2×240
860387	2222	72	2×4.50	2×180	2×288

## Type 6: LaneLED GFK redundant, 4'400K, 21 -32VDC, 300Lux-95 cm

860509	374	12	2×1.5	2×60	2×96
860510	1112	36	2×4.5	2×180	2×288
860483	1481	48	2×6.0	2×240	2×384
860512	1850	60	2×7.5	2×300	2×480
860513	2222	72	2×9.0	2×360	2×576
860718	2958	96	2×12.0	2×480	2×768

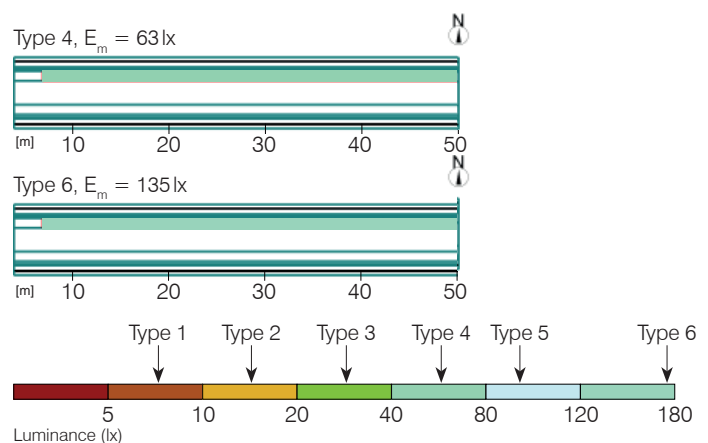
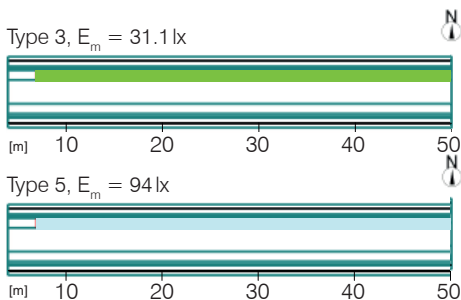

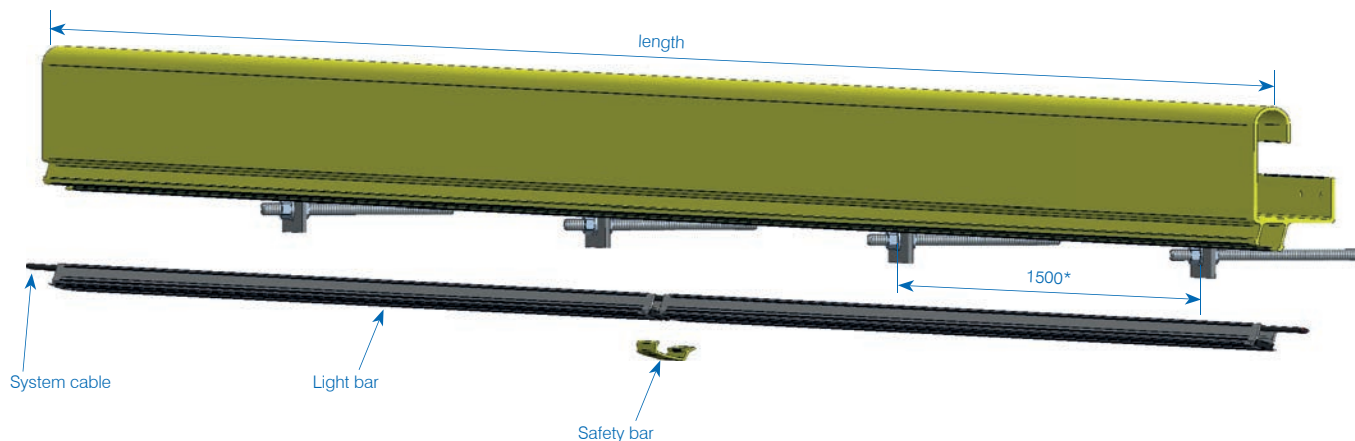

## Handrail GFK

The MC50 profile was selected so that it can serve as handrail, as carrier element for the LED bars with integrated cable tray for system cable as well as provided with an external integrated cable tray.

- handrail material in yellow signal colour
- perfect accessories for a quick and easy assembly
- many specific items for special solutions

## Handrail composition

The handrail profile is the core element of the composition. The LaneLED light bar (which is connected to the system cable) is clicked into the integrated cable tray from below. A safety bracket is used inbetween 2 LaneLED light bars to fix.

## Handrail for self-rescue

- handrail 130×93 mm made from glass fibre reinforced plastic (GRP)
- halogen-free, standard length = 6'000 mm, colour RAL 1023
- multifunctional with integrated cable tray for quick mounting (click-in) of the LaneLED luminaires and system cable as well as an external integrated cable tray
- impact resistant, hardly flammable, self-extinguishing, halogen-free
- assembly with threaded bolt, support gap 1.5 m (or according to manufacturer's specification)

## Handrail MC50

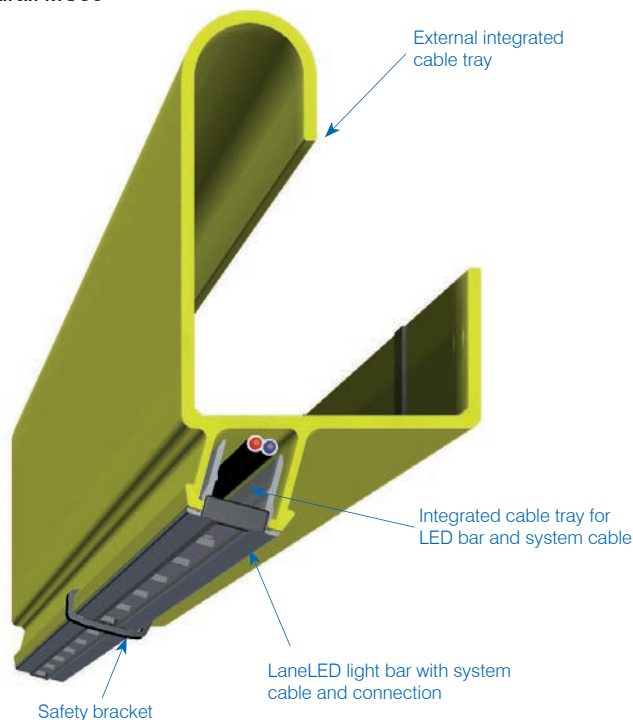

# Technical data/Product range handrail

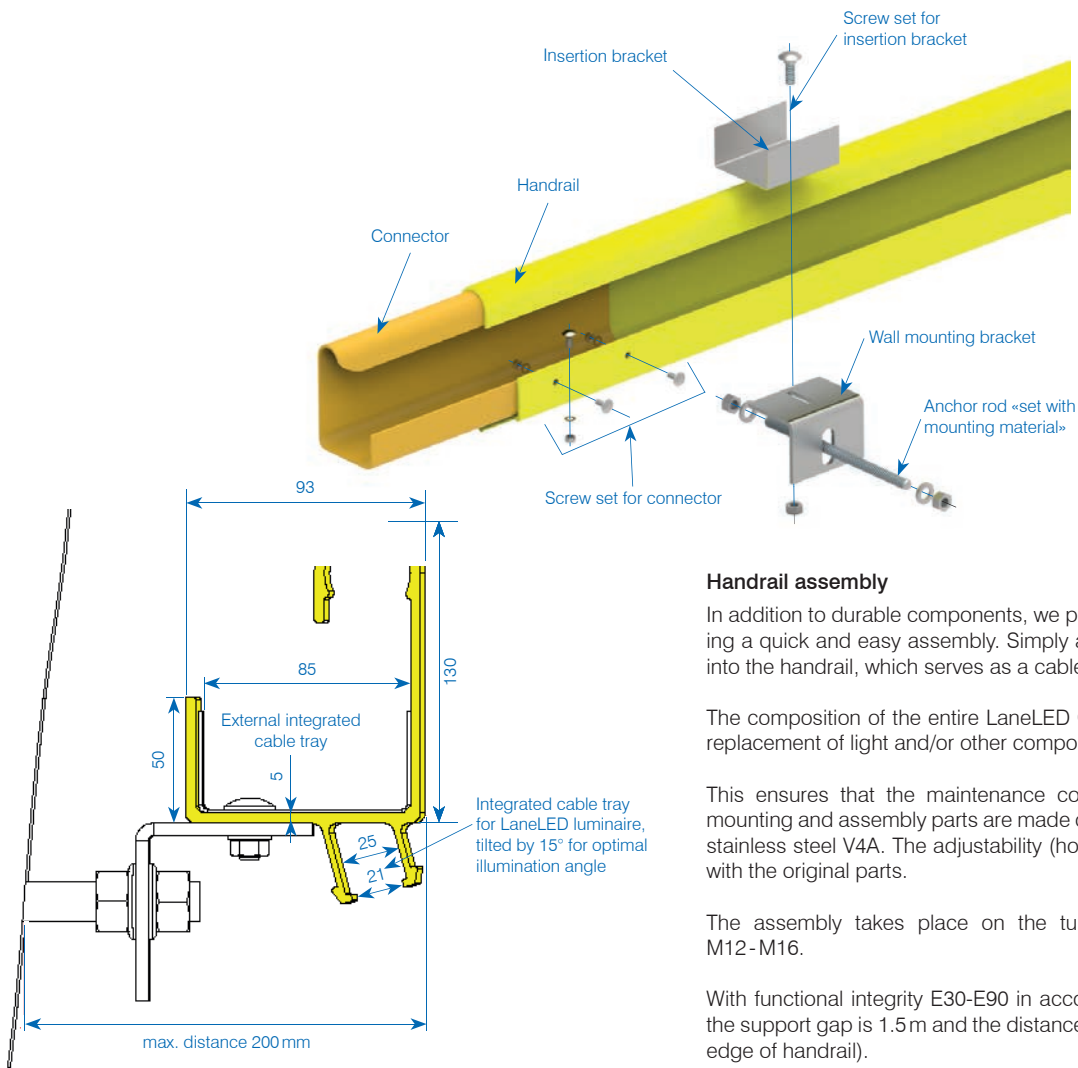

## Handrail assembly

In addition to durable components, we paid particular attention to ensuring a quick and easy assembly. Simply allow the LED light bars to click into the handrail, which serves as a cable tray at the same time.

The composition of the entire LaneLED GFK is designed for a possible replacement of light and/or other components.

This ensures that the maintenance costs can be kept very low. All mounting and assembly parts are made of dimensionally stable material, stainless steel V4A. The adjustability (horizontal and vertical) is ensured with the original parts.

The assembly takes place on the tunnel wall with threaded bolts M12-M16.

With functional integrity E30-E90 in accordance with DIN 4102 part 12, the support gap is 1.5m and the distance to the wall 200mm max. (outer edge of handrail).

## Assortment LaneLED GFK

Item no.	Description
140336	Handrail type MC50LED, L=6000mm 130×93×6000 mm, GFK yellow Ral 1023, connector incl.
178634	Handrail type MC50LED, L=2500mm 130×93×2500 mm, GFK yellow Ral 1023
117164	Safety bracket, L= 90mm GFK yellow Ral 1023
138874	Safety bracket, L= 90mm, with hole Ø18mm GFK yellow Ral 1023
140338	Connector, L=400mm GFK yellow Ral 1023, without screw set
149653	Screw set connector, M6, 6 pieces (VE100)
140328	Insertion bracket V4A, 100×84/45×1.5mm
140331	Screw set insertion bracket M8, 1 pieces (VE100)
140330	Wall mounting bracket V4A, 100×70×5mm
174464	Cover plastic, L=3000mm, grey / for handrail MC50LED
174465	Lid spring V4A, for cover MC50LED
178975	Anchor rod V4A, M16×150mm, including incidentals
178977	Anchor rod V4A, M16×200mm, including incidentals
177407	Anchor rod V4A, M16×300mm, including incidentals
177409	Injection mortar 500 ml to anchor rods for: 30 pieces M16 / 40 pieces M12

## Insertion bracket

## Wall mounting bracket

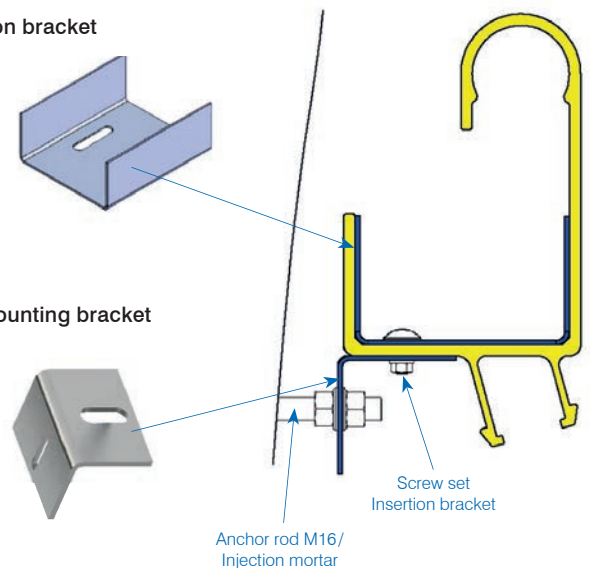

## Tunnel overview

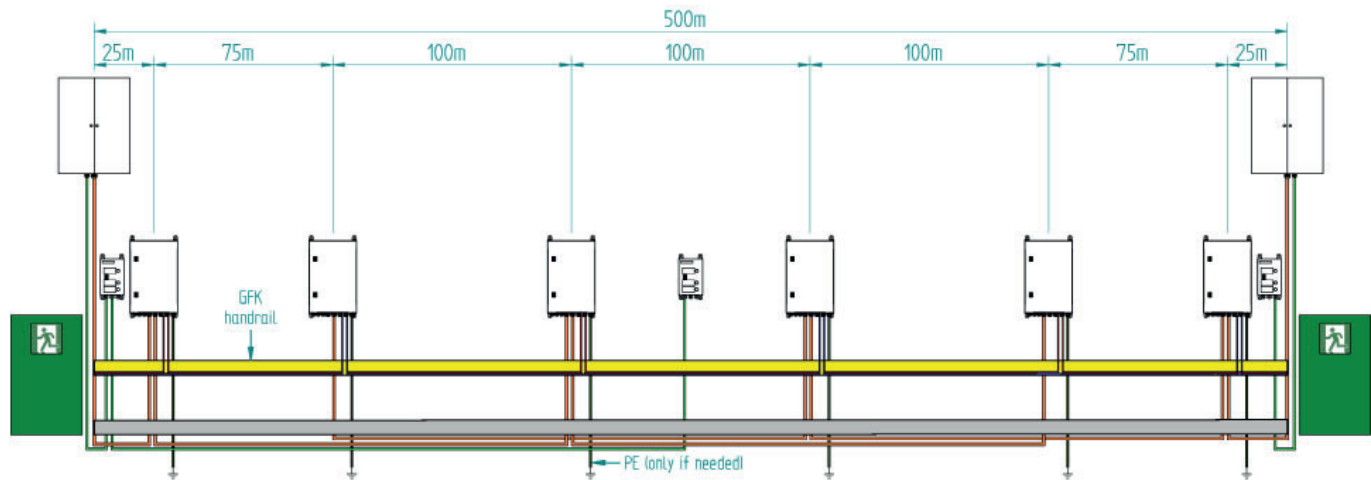

## Control unit (item no. 255587)

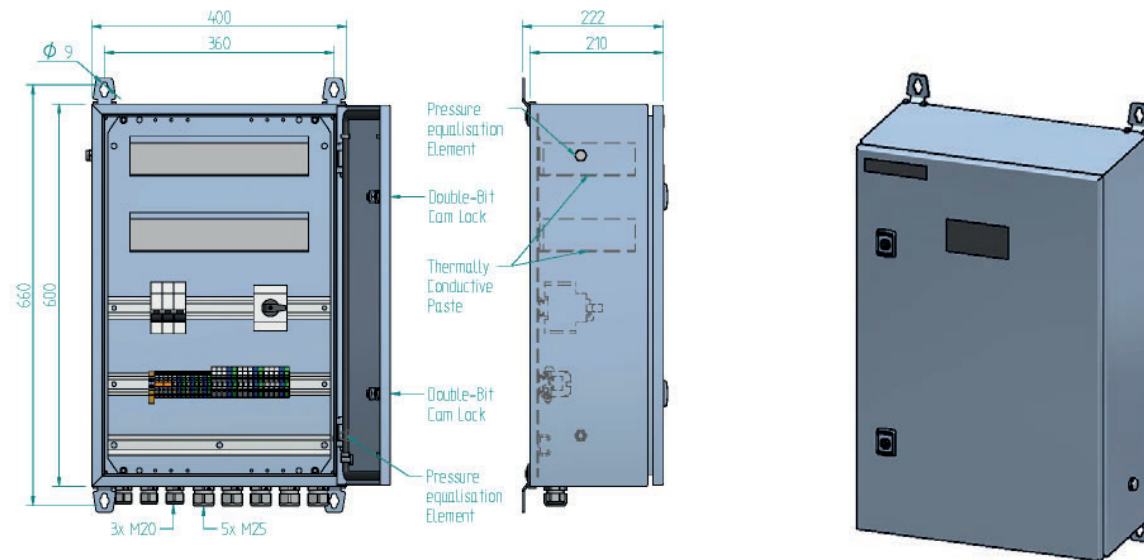

## Operating unit (item no. 255586)

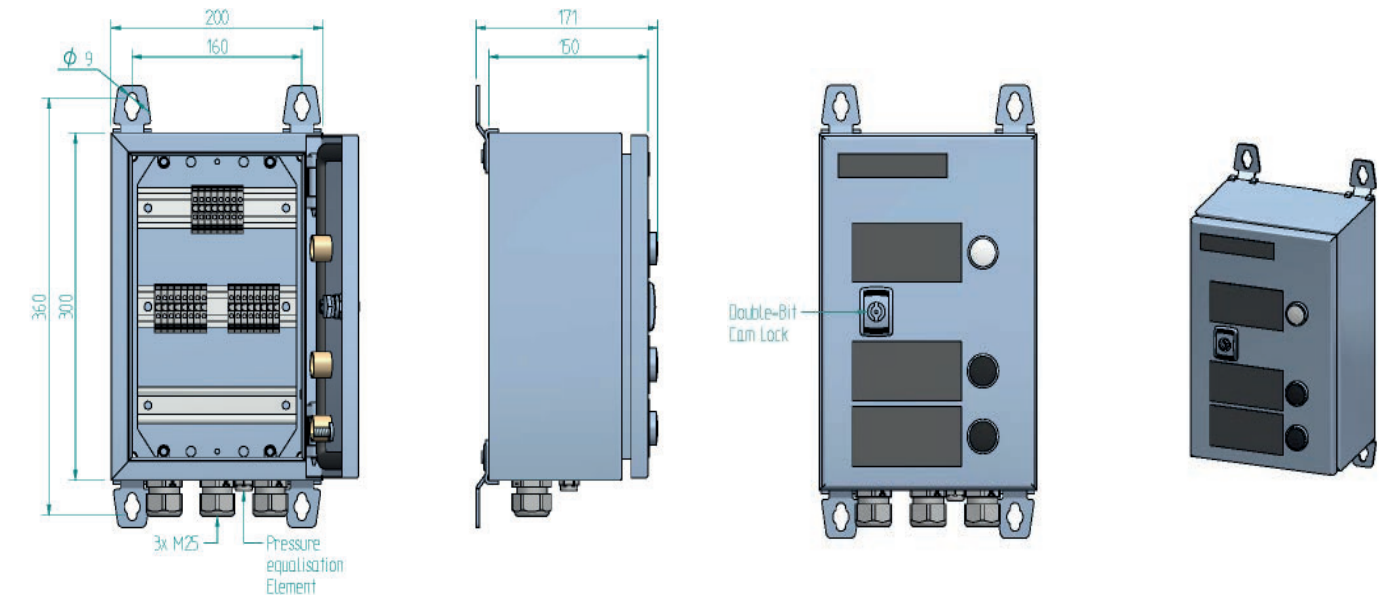



## Feeding unit without alarm unit (Item no. 134388)

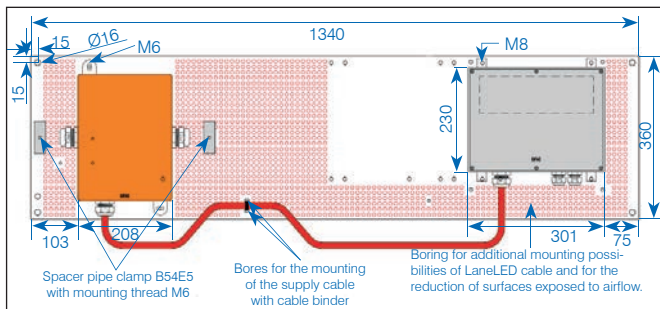

## Example feeding units

Item no.	Description
130352	LaneLED, feeding unit E30/E90 complete to plate V4A BFA, alarm (ME+A at the front), power supply unit 2x240W
134388	LaneLED, feeding unit E30/E90 complete to plate V4A BFA, power supply unit 240W
177406	LaneLED, anchor rod V4A, M12x200 mm, including incidentals
177409	LaneLED, injection mortar 500ml to anchor rods for: 30 pieces. M16/ 40 pieces. M12

Other versions on request

## Examples for power supply cabinet



Item no. 188456



Item no. 192834

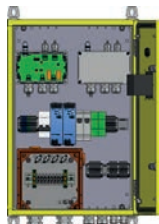

Item no. 193933

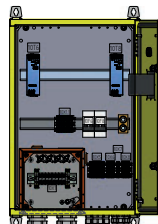

Item no. 213219

Item no.	Description
188456	LaneLED, power supply cabinet, 1.4301 (V2A) RAL 1023 (yellow signal colour), 400x645x260.8 mm 2 power supplies 230VAC/24VDC-20W, IP66
192834*	LaneLED, power supply cabinet, 1.4301 (V2A) RAL 1023 (yellow signal colour), 400x645x261 mm 2 power supplies 230VAC/24VDC-240W, IP66
193933*	LaneLED, power supply cabinet, 1.4301 (V2A) RAL 1023 (yellow signal colour), 400x645x261 mm 2 power supplies 230VAC/24VDC-240W, IP66
213219**	LaneLED, power supply cabinet, 1.4301 (V2A) RAL 1023 (yellow signal colour), 400x645x260.8 mm 2 power supplies 230VAC/24VDC-240W, IP66

Other versions on request

\* plus failure monitoring when switched off (cold conductor monitoring), failure monitoring during operation (current monitoring relay) and power supply feedback via DC-OK contact

\*\* power supply feedback via DC-OK contact

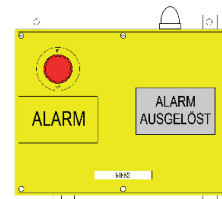

Item no. 136104

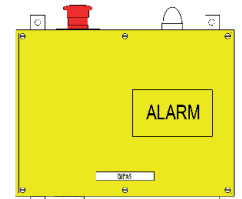

Item no. 136136

## Spare units for SRM\* SBB AG

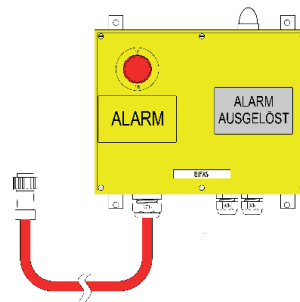

Item no. 155622

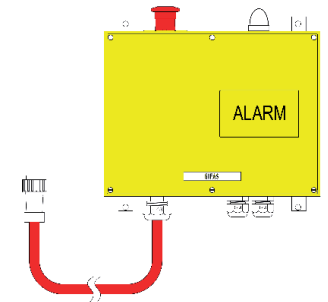

Item no. 155624

\*SRM = self-rescue measure

## Standard item control-/alarm unit

Art.-Nr.	Description
136104	LaneLED, alarm unit, plastic, 300x230x110mm, with alarm button at the front, with display at the front, IP66
136136	LaneLED, alarm unit, plastic, 300x230x110mm, with alarm button above, without display, IP66
155622	LaneLED, alarm unit, plastic, 300x230x110mm, with alarm button at the front, with display at the front, IP66, with connection cable
155624	LaneLED, alarm unit, plastic, 300x230x110mm, with alarm button above, without display, IP66, with connection cable

Other versions on request



## Cable

The trunk or feeder cables are chosen project specific: With/without callback, fireproof cabling to FE180/E90 or FE05 finish. We are happy to support you!

Item no.	Description
141138	LaneLED, high voltage cables FE180/E90 Hybrid, black, 5x6mm <sup>2</sup> (LNPE) +3x1.5mm <sup>2</sup> (1-3), Ø29.4 mm
178362	LaneLED, supply cable FE180/E90, orange, 5x6mm <sup>2</sup> (LNPE), Ø20.1 mm
115421	LaneLED, supply cable FE180/E30, orange, 5x6mm <sup>2</sup> (LNPE), Ø14.2 mm
037552	LaneLED, control cables FE180/E30, orange, 3x2.5mm <sup>2</sup> (LNPE), Ø9.9 mm
132930	LaneLED, control cables FE180/E30 orange, 7x1.5mm <sup>2</sup> (Num.+PE), Ø11.5 mm

Other versions on request

## Our services

- planning and concept development as per specifications
- creation of object-specific plans and documents
- lux lighting calculation
- consultation and support through our project managers
- mutual support among the partner companies, contact mediation
- assembly support on site

## Assembly

- Ask for our detailed assembly instructions!

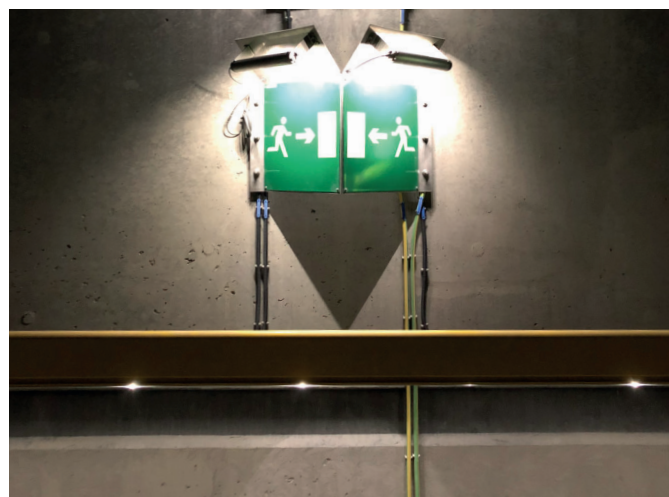

## Assembly equipment for rent

Item no.	Description
138174	LaneLED, assembling jig for feeding unit
138291	LaneLED, mounting aid V2A GFK with 2 reels
138524	LaneLED cable reel trolley for cable reels with max. dim. Ø500×500
176955	Wall scanner for detecting iron
137634	LaneLED GFK mounting aid, aluminium, 270×50×40mm
860565	Crimping tool mechanical for current collector/system cable
179280	Battery pack 24V, 7.2Ah

Other versions on request





Overall view of SBB-cross city link Zurich



Glatscheras-Tunnel RhB

Image: Nadja Simmen/Die Südostschweiz



Installation tunnel Ruckhalde Appenzeller Bahnen



Direction display for emergency escape route

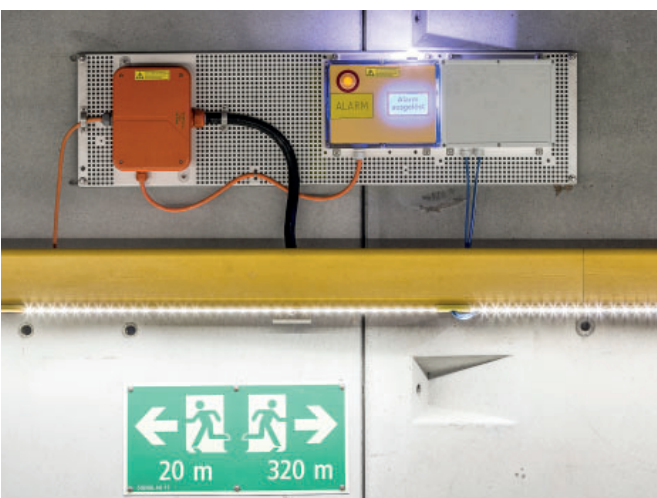

Alarm unit



Alarm unit

GET IN TOUCH WITH US

News about the assortment and specific solutions  
you can find on our website:

[www.gifas.ch](http://www.gifas.ch)

We reserve the right to make technical modifications. V0624



**GIFAS**  
ELECTRIC

**Malux**  
solutions

GIFAS-ELECTRIC GmbH  
Dietrichstrasse 2  
CH-9424 Rheineck

+41 71 886 44 44  
+41 71 886 44 49  
info@gifas.ch  
[www.gifas.ch](http://www.gifas.ch)